



RCN DIGITAL CABLE USERS GUIDE



Congratulations!

Thanks to your new Digital Cable Service, you now have access to the most cutting-edge cable television services available, only from RCN.

At RCN, we're committed to providing you with exceptional services at a value you just can't get from the competition. And no where else is that commitment more evident than in your new digital converter. Because we didn't just lease a converter from another company like other cable companies do. We spoke to our customers. And then built our own based on your feedback. As a result, your new digital converter is more interactive, more user-friendly and simply more in-tune with your cable television needs.

We invite you to take a look at the following pages. Throughout, you'll find helpful information regarding your cable TV service, so be sure to check here first when you have a question, need help connecting your converter, or require assistance with any of the new features of your new converter, such as using Starview, ordering Impulse ON-DEMAND, etc.

We've tried to think of everything. Of course, if you require further assistance, please feel free to call 1.800.RING.RCN.

We wish you many long hours of entertainment!

Remote Control

Please refer to the remote control user manual to operate the remote control.



“VCR” Functions for Video on Demand with this remote:

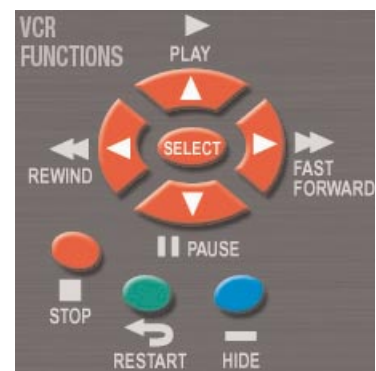



Front Panel of Set Top Box

1

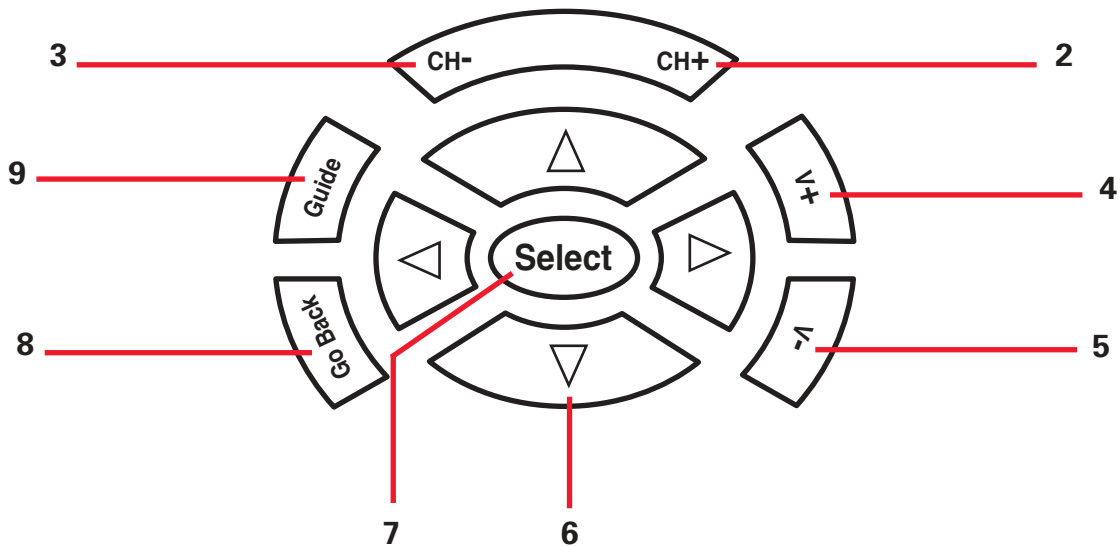

- | | | |
|----------|------------------|---|
| 1 | Standby | Switches between operation and standby modes. |
| 2 | CH+ Channel Up | Selects the next channel in the list. |
| 3 | CH- Channel Down | Selects the previous channel in the list. |
| 4 | V+ Volume Up | Increases the volume level. |
| 5 | V- Volume Down | Decreases the volume level. |
| 6 | Arrows | Used for navigating in the Interactive Program Guide and channel banner. |
| 7 | Select | Confirms selection and saves settings and preferences in the Interactive Program Guide OR invokes the Interactive Program Guide during normal TV viewing. |
| 8 | Go Back | Returns to previous screen. |
| 9 | Guide | Invokes the TV Listings daily programming schedule. |

SET TOP BOX: REAR PANEL

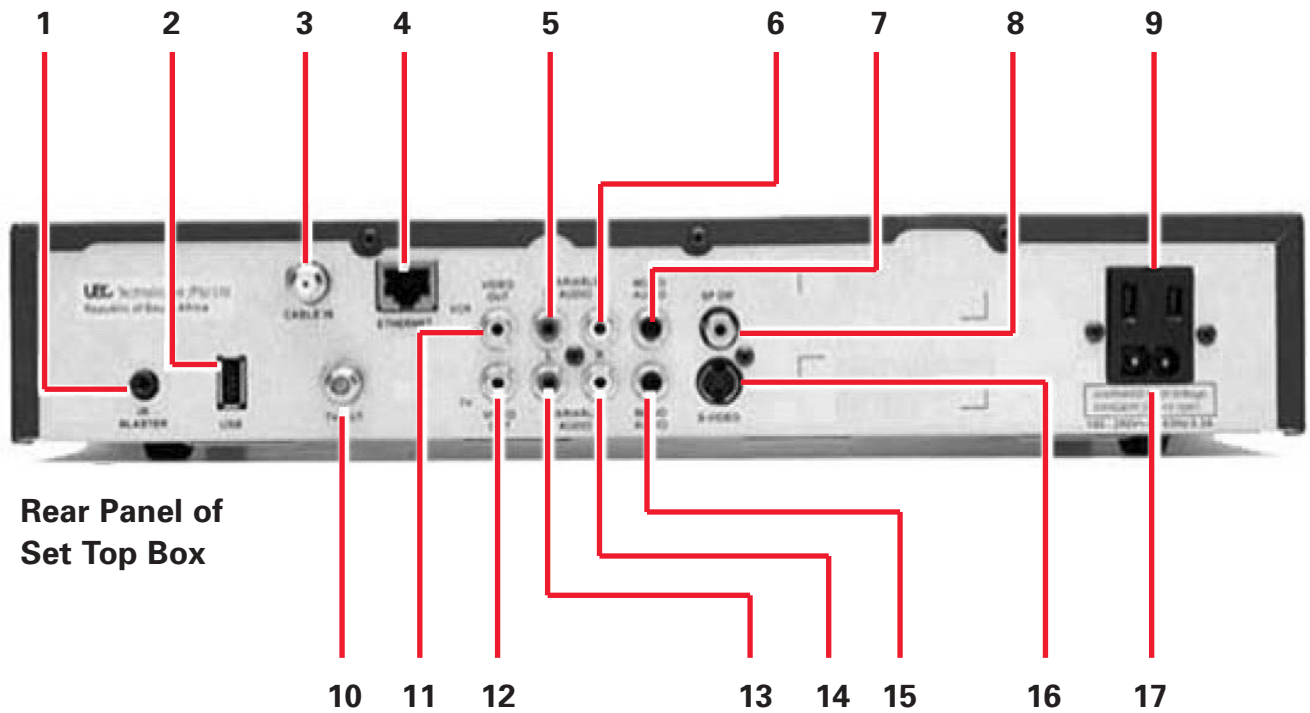

Rear Panel of Set Top Box

- | | | | | | |
|-----------|----------------------|-------------------|-----------|----------------------|--------------------------|
| 1 | IR Blaster | For future use | 11 | VCR Video Out | |
| 2 | USB | For future use | 12 | TV Video Out | 2nd video out (DVD etc.) |
| 3 | Cable In | | 13 | Variable Audio Left | For TV |
| 4 | Ethernet | | 14 | Variable Audio Right | For TV |
| 5 | Variable Audio Left | For VCR | 15 | Variable Mono Audio | For TV |
| 6 | Variable Audio Right | For VCR | 16 | S-Video Out | |
| 7 | Variable Mono Audio | For VCR | 17 | Power In | |
| 8 | SP DIF | Digital Audio Out | | | |
| 9 | Power Out | A/C plug | | | |
| 10 | TV Out | | | | |

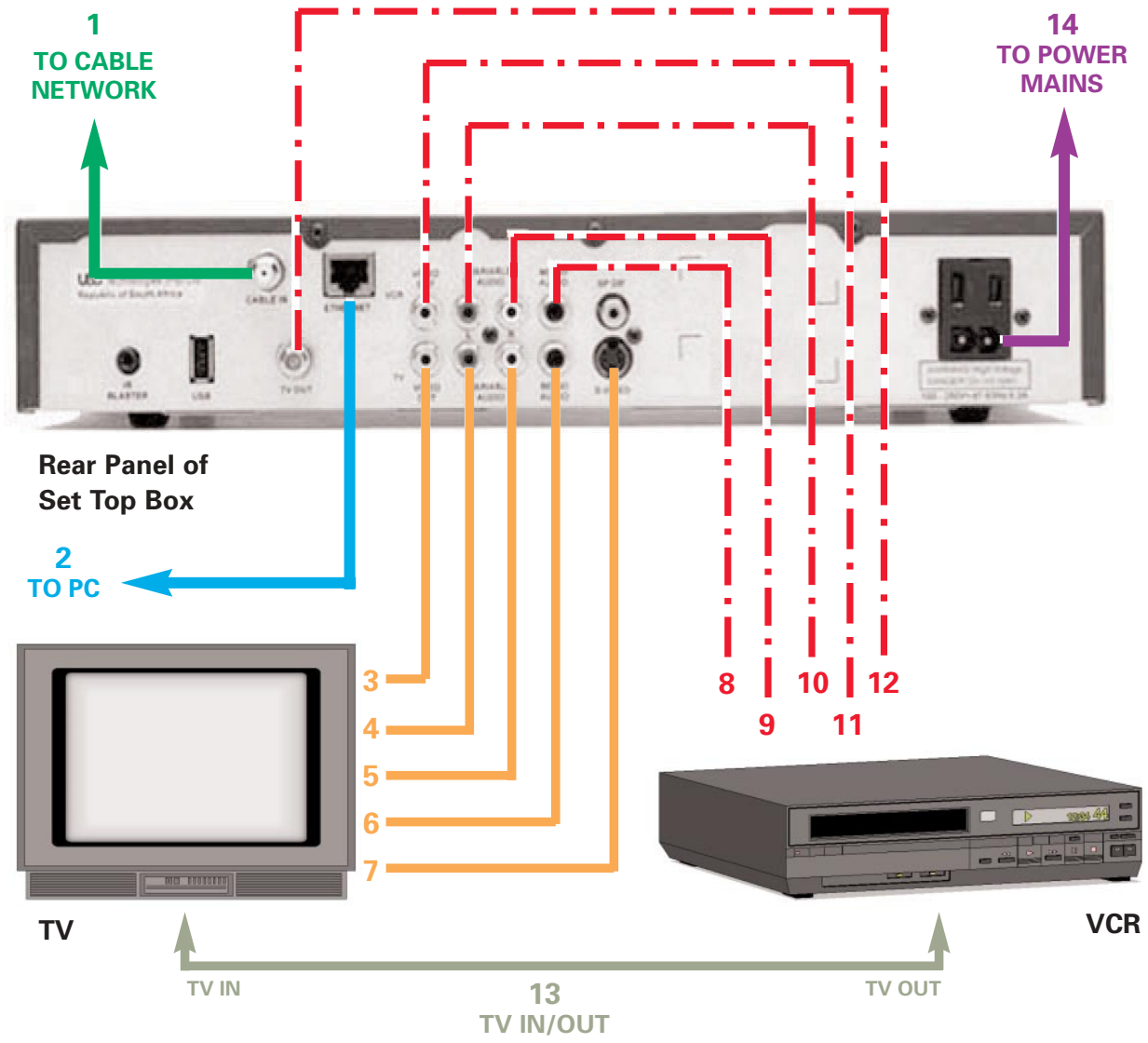

- 1** Connect the **CABLE IN** connector on the **CONVERTER BOX** to the cable network.
- 2** Connect the **ETHERNET** connector on the **CONVERTER BOX** to your **PC**.
- 3** Connect the **TV VIDEO OUT** connector on the **CONVERTER BOX** to the **VIDEO IN** connector on the **TV**.
- 4** Connect the **TV LEFT AUDIO** connector on the **CONVERTER BOX** to the **AUDIO LEFT** connector on the **TV**.
- 5** Connect the **TV RIGHT AUDIO** connector on the **CONVERTER BOX** to the **RIGHT AUDIO** connector on the **TV**.
- 6** Connect the **MONO AUDIO** connector on the **CONVERTER BOX** to the **MONO AUDIO** connector on the **TV**.
- 7** Connect the **S-VIDEO** connector on the **TV** to the **S-VIDEO** connector on the **CONVERTER BOX**.

- 8** Connect the **VCR MONO AUDIO** connector on the **CONVERTER BOX** to the **MONO AUDIO** connector on the **VCR**.
- 9** Connect the **VCR RIGHT AUDIO** connector on the **CONVERTER BOX** to the **RIGHT AUDIO** connector on the **VCR**.
- 10** Connect the **VCR LEFT AUDIO** connector on the **CONVERTER BOX** to the **LEFT AUDIO** connector on the **VCR**.
- 11** Connect the **VCR VIDEO OUT** connector on the **CONVERTER BOX** to the **VIDEO IN** connector on the **TV**.
- 12** Connect the **TV OUT** connector on the **CONVERTER BOX** to the **TV IN** connector on the **VCR**.
- 13** Connect the **TV OUT** connector on the **VCR** to the **TV IN** connector on the **TV**.
- 14** Connect the **POWER IN** on the **CONVERTER BOX** to the **POWER OUTLET**.

CONNECTIONS: SET TOP BOX, TV, HOME THEATER

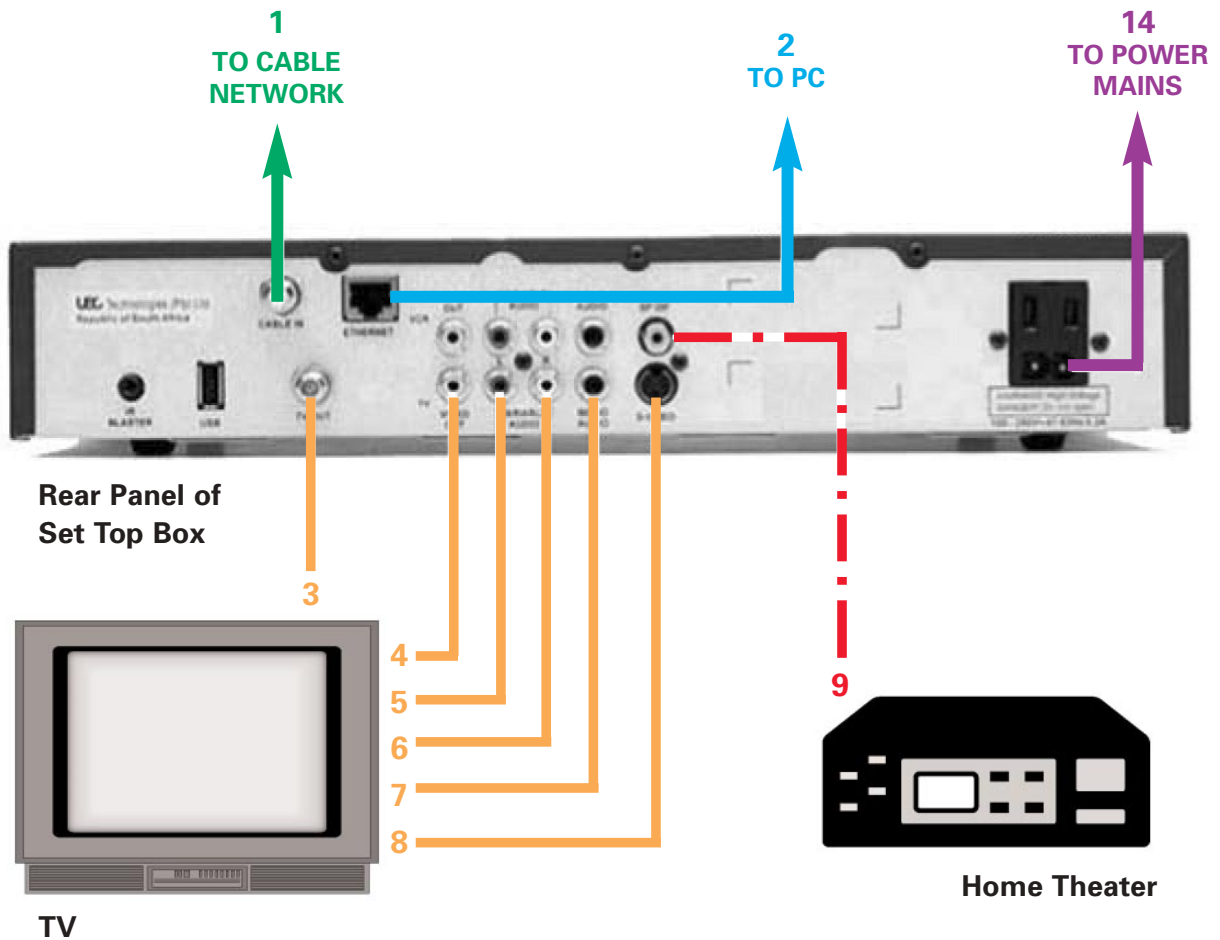

- 1** Connect the **CABLE IN** connector on the **CONVERTER BOX** to the cable network.
- 2** Connect the **ETHERNET** connector on the **CONVERTER BOX** to your **PC**.
- 3** Connect the **TV OUT** connector on the **CONVERTER BOX** to the **TV IN** connector on the **TV**.
- 4** Connect the **TV VIDEO OUT** connector on the **CONVERTER BOX** to the **VIDEO IN** connector on the **TV**.
- 5** Connect the **TV LEFT AUDIO** connector on the **CONVERTER BOX** to the **AUDIO LEFT** connector on the **TV**.
- 6** Connect the **TV RIGHT AUDIO** connector on the **CONVERTER BOX** to the **RIGHT AUDIO** connector on the **TV**.
- 7** Connect the **MONO AUDIO** connector on the **CONVERTER BOX** to the **MONO AUDIO** connector on the **TV**.
- 8** Connect the **S-VIDEO** connector on the **TV** to the **S-VIDEO** connector on the **CONVERTER BOX**.
- 9** Connect the **SP DIF** (Digital Audio) connector on the **CONVERTER BOX** to the **SP DIF** (Digital Audio) connector on the Home Theater System.
- 10** Connect the **POWER IN** on the **CONVERTER BOX** to the **POWER OUTLET**.

INTERACTIVE PROGRAMMING GUIDE



The Interactive Program Guide (IPG) is an on-screen, user-friendly, multi-functional guide that is designed to help you locate the programming you want to watch, and set up the functions of the set-top box to your preferences; **the IPG allows you to view programs transmitted by RCN, navigate to programs, purchase and set reminders for programs, view information, define preferences, etc.**

NOTE: The IPG is set to display time based on the 24-hour clock; you must set it for U.S. time.

MAIN MENU DIRECTORY OF SERVICES

The main control for the IPG is the **Main Menu**. To access the Main Menu, press **Select** while viewing a program. The following screen is displayed:



The **Main Menu** gives access to screens where you can view information and select options.

The **Main Menu** screen is divided into 3 areas (see Figure 1 above):

- **Service Menu** This menu, located horizontally across the screen, has a text button naming each menu item. One button is always selected and highlighted. Use the ◀ or ▶ arrow buttons on the remote control to scroll through the menu icons.
- **Menu Options** This menu, located horizontally across the screen, lists the options available for the menu items selected in the Service Menu. Use the ▲ or ▼ arrow buttons on the remote control to scroll up and down the menu options. To select an option, highlight the option you want, and press **Select** on the remote control. When an option is selected, a new screen is displayed.
- **Video Window** The video window displays the channel currently being viewed, with the accompanying audio for that channel or program. If a different channel or program is selected through the Main Menu, press **Select** to display the newly selected channel or program.

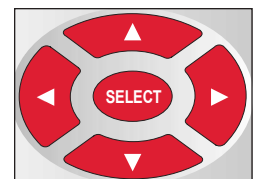

Use the arrows and **SELECT** on the remote to navigate onscreen.

The **Service Menu** gives options for access to:

CHANNELS

The **CHANNELS** option in the Main Menu displays the titles of all the channels you subscribe to.

To access the **CHANNELS** option do the following:

- 1 While in normal viewing mode, press **Select** on the remote control.
The following screen is displayed:



CHANNELS
(Figure 2)

- 2 Use the ◀ or ▶ arrow buttons to highlight the **CHANNELS** button in the Service menu. When **CHANNELS** is highlighted, the **Menu Options** (the left part of the screen) displays channel selections. *See Figure 2 above.*
- 3 The titles of all the channels will be displayed in the **Menu Options** area of the IPG. Press **Select** to see the currently highlighted channel in the video window.
- 4 Use the ▲ or ▼ arrow keys to scroll through channel titles. To view the video of any channel in the video window, highlight the title of the channel and press **Select** on the remote control.
- 5 To exit the IPG and return to normal viewing, press **Select** on the remote control.



GUIDE

The **GUIDE** option in the Main Menu gives you access to these options:

- Impulse ON-DEMAND
- TV Listings
- Favorite Channels
- Categories
- Reminders
- Digital Music Channels

To access the **GUIDE** option, do the following:

- 1 While in normal viewing mode, press **Select** on the remote control. The Interactive Program Guide (IPG) is displayed.

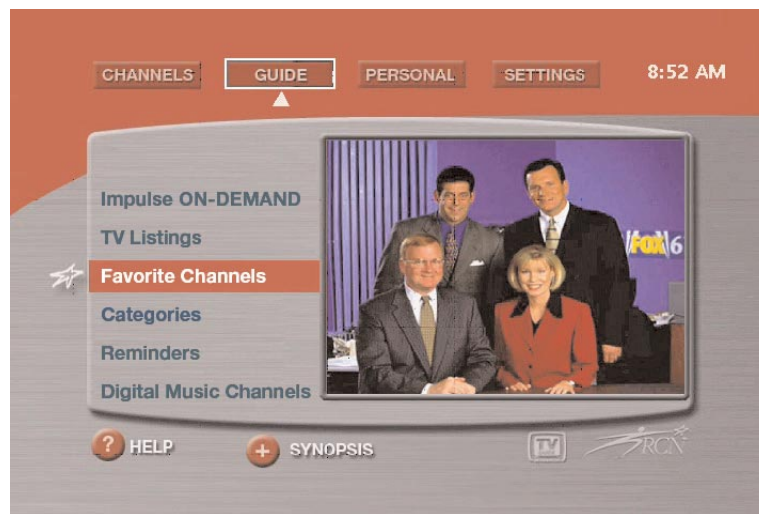

GUIDE
(Figure 3)

- 2 Use the ◀ or ▶ arrow buttons to highlight the **GUIDE** button in the Service Menu. When **GUIDE** is highlighted, the Menu Options (the left part of the screen) changes. *See Figure 3 above.*
- 3 Use the ▲ or ▼ arrow keys to scroll through the options in the **GUIDE**. Highlight and press **Select** to access an option in the **GUIDE**.

TV LISTINGS

TV Listings gives you the daily programming schedule for all the channels. This includes channel numbers, channel names, titles of programs, start time of programs and an option to view the synopsis of the highlighted program.

To access **TV Listings**, do the following:

- 1 While in the **GUIDE** use the ▲ or ▼ arrow key and highlight **TV Listings**. Press **Select**. The following screen is displayed. See Figure 4.



GUIDE
The **TV Listings** can also be accessed by pressing **GUIDE** on the remote control while in normal viewing.

Today	8:30	9:00	9:30	8:49 AM
430 US Comedy	Fr Friends		Frazier	
440 US Comedy Gold	C Bilko		Bilko	
900 NDS News	Local Roundup	The world this Week		
919 NDS News	Local Roundup	The world this Week		
920 Sky Movies Gold	T Birds		Vertig o	

At the bottom of the screen are buttons for BACK, SYNOPSIS, and a TV icon with the RCN logo.

TV LISTINGS
(Figure 4)

- 2 Use the ▲ or ▼ arrow keys to scroll through the channels, and use the ◀ or ▶ arrow keys to scroll through the start times of programs. Use the channel ▲ or ▼ buttons to page up and down through the channel listing. See Figure 4 above.
- 3 To view the **SYNOPSIS** of a program, highlight the program, and press + on the remote control.
- 4 Press **GO BACK** on the remote control to return to TV Listings or press **EXIT** to return to normal viewing.
- 5 To view the **START TIME** and the day a specific program is shown, press ? on the remote control.
- 6 Press ? or **GO BACK** to remove the banner that displays day and start time of program.
- 7 Press **GO BACK** to return to **IPG** (if TV Listings selected through the **IPG**), or press **Select** to return to normal viewing.

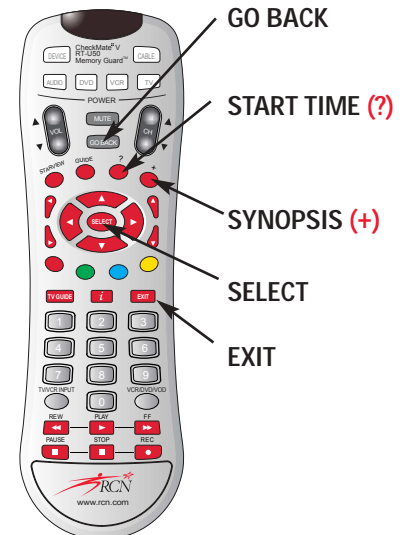



FAVORITE CHANNELS

The **Favorite Channels** option allows you to place your favorite channels in one list so that they will be easily available to you. Your **Favorite Channels** will be duplicated/located on channels 900 through 919.

To access **Favorite Channels** do the following:

- 1** Press **GUIDE** on the remote control. Use the ▲ or ▼ arrow key and highlight **Favorite Channels**. Press **Select**.
- 2** On the right half of the **Favorite Channels** screen are the titles of all the available channels (without their number). The left half is where your favorite channels will be listed.
- 3** To place your favorite channels in one list, first ensure that you are able to scroll through the **MY FAVORITES** list of the screen using the ▲ and ▼ arrow keys. You will only be able to scroll through the **MY FAVORITES** list of the screen when the white arrow (▶) points to the right. If it is not pointing to the right, press ▶ (right arrow) on the remote control.
- 4** Use the ▲ or ▼ key to highlight ***none***. Press **Select**. The white arrow in the middle will now face left. This would mean that you can now scroll through the **CHOICES** list on the right half of the screen using the and arrow keys ▲ and ▼.
- 5** Scroll through the **CHOICES** list and choose a channel that you would like placed in your favorites list. Press **Select**. The channel will move to the **MY FAVORITES** half of the screen.
- 6** Repeat steps 3 to 5 until all of your favorite channels are placed in the **MY FAVORITES** list.
- 7** Press **GO BACK** to return to the **GUIDE**, or press **EXIT** to return to normal viewing.

CATEGORY

The **Category** option enables you to view the titles of movies and programs in their specific categories or genre.

To access the **Category** option do the following:

- 1** While in the **GUIDE** use the ▲ or ▼ arrow key and highlight **Category**. Press **SELECT**.
- 2** There are 2 lists displayed in the **Select Category** screen. The list on the left displays the category or genre of movies or programs. The list on the right displays the types of movies in a specific category or genre, e.g., on the screen above, the category that is highlighted on the left is **Children's**. The list on the right displays the types of programs or movies in the children's category, such as **Animated Comedy, Cartoons & Animations** etc.
- 3** To scroll through the list on the left using the ▲ or ▼ arrow keys, first ensure that the white arrow (▶) in the middle of the screen is pointing to the right. If it is pointing to the left, press the ◀ (left) arrow key on the remote control. The arrow on the screen will now point right.
- 4** Use the ▲ and ▼ arrow keys to scroll through the list on the left. You will notice that as you scroll through the list on the left, the list on the right also changes, giving you the types of movies or programs in that highlighted category or genre.
- 5** To scroll through the list on the right, first press the ▶ (right) arrow key so that the white arrow in the middle of the screen points to the left. Now use the ▲ or ▼ arrow key to highlight a type of program or movie in the highlighted category or genre. To view the titles of the movies or programs, press **Select**.
- 6** Press **GO BACK** to return to the **Category** screen, press **EXIT** to return to the last channel viewed, or press **Select** to view the currently highlighted channel in the **Select Program** screen.



REMINDERS

The **Reminders** option allows you to view a list of all the programs you would like to be reminded of for future viewing. Programs with **Reminders** cannot be watched before their start times.

To view all the programs you have set **Reminders** for, do the following:

- 1** While in the GUIDE use the ▲ or ▼ arrow key and highlight **Reminders**. Press **Select**.
- 2** You will see a screen that displays the **Reminders**, the day they are being broadcast and their start times.
- 3** Highlight a program using the ▲ or ▼ arrow. Press **Select** to set or unset the highlighted program as a reminder.
- 4** Highlight a program and press + to view a **Synopsis**.
- 5** Press **GO BACK** to return to the IPG , or press **EXIT** to return to normal viewing.

To set reminders through TV listings:

- 1** Press **Select** to access the Interactive Program Guide.
- 2** Highlight **Select** in the Service Menu at the top of the screen.
- 3** To select the desired channel use the ► (right) arrow key to highlight the desired program.
- 4** Press **Select**.
- 5** In the **Reminders** screen, press **Select** so that a check mark appears in the black box next to the name of the program.
- 6** Press **Go Back** to return to the **TV Listings** screen.
- 7** **TV Listings** screen highlights program in light red.

DIGITAL MUSIC CHANNELS

The **Digital Music Channels** option displays the music channels menu, which provides a way to access commercial-free, digital music by category.

To access **Digital Music Channels**:

- 1 While in normal viewing mode, press **Select** on the remote control. The main IPG screen is displayed.
- 2 Press the ▲ or ▼ arrow button to highlight Digital Music Channels. Press **Select**. The Digital Music Channels screen is displayed.
- 3 The **Digital Music Channels** menu lists the individual music channels available. Use the ▲ or ▼ arrow buttons to highlight the channel you want to listen to. Press **Select** and tune to the channel highlighted.
- 4 Press **GO BACK** on the remote control to return to the **GUIDE**, or press **EXIT** to return to normal viewing.

PERSONAL

The **PERSONAL** option in the **Main Menu** enables you to set up some features of the RCN Digital Cable Service to your preference.

To access the **PERSONAL** option, do the following:

- 1 While in normal viewing mode, press **Select** on the remote control.
- 2 Use the ◀ or ▶ arrow key to highlight the **PERSONAL** button in the **Main Menu**. When **PERSONAL** is highlighted, the **Menu Options** (the left part of the screen) changes.
- 3 The options that you are able to set your personal preferences for are:
 - Parental Lock
 - Guide to Content Icons
 - Select Four-Digit Code
 - Account Status
 - Pay-Per-View Account
 - Pay-Per-View PIN
 - Set Pay-Per-View Limit
 - SAP Preference
 - SAP Preference 2
 - Stereo Settings
 - Reminder Settings
 - Banner Duration
 - Customer Service

*Some options listed above may not yet be available.



PARENTAL LOCK

Parental Lock allows you to prevent viewing of programming based on rating.

To access **Parental Lock**:

- 1 While in normal viewing mode, press **Select** on the remote control. The main IPG screen is displayed.
- 2 Use the ◀ or ▶ arrow key to highlight the **PERSONAL** button in the **Service** menu.
- 3 Press the ▲ or ▼ arrow key to highlight **Parental Lock**. Press **Select**. The **Parental Lock** screen (Figure 5) is displayed.

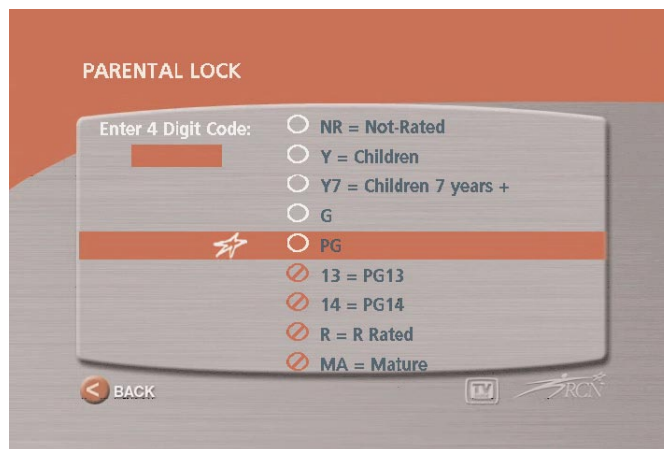

PARENTAL LOCK
(Figure 5)

Note: NR, Not Rated, could contain adult content.

- 4 A 4-digit PIN is required to access the parental ratings. **The default 4 digit PIN is 0000.** Once the **Parental Lock** screen is displayed, enter the 4 digit PIN and press **Select**. You will now have access to the parental ratings.
- 5 Ratings are listed in order of least offensive (Y) to most offensive (X). Highlight the maximum rating you would like to allow to be viewed and press **Select**. Programming that is rated above the selected rating will be blocked and unviewable. While viewing TV, you will be asked to enter the 4-digit PIN to view blocked programs.
- 6 Enter the 4-digit PIN and press **Select**. The program will now be unblocked.
- 7 Please note that if you enter in the wrong PIN to gain access to the parental ratings or the blocked programs, a screen informing you that the incorrect PIN was entered will be displayed.
- 8 Press **GO BACK** on the remote control, enter the correct PIN and press **Select**.

GUIDE TO CONTENT ICONS

The **Guide to Content Icons** option displays the content icons and what they represent.

To access **Guide to Content Icons**:

- 1 While in normal viewing mode, press **Select** on the remote control. The main IPG screen is displayed.
- 2 Use the ◀ or ▶ arrow key to highlight the **PERSONAL** button in the **Service** menu.
- 3 Press the ▲ or ▼ arrow key to highlight **Guide to Content Icons**. Press **Select**. The **Guide to Content Icons** screen is displayed.
- 4 Press **GO BACK** to return to **IPG**, or press **Exit** to return to normal viewing.

SELECT 4-DIGIT CODE

The **Select 4-Digit Code** option allows you to set your personal 4-digit code for features such as **Parental Lock** etc.

To access **Select 4-Digit Code**:

- 1 While in normal viewing mode, press **Select** on the remote control. The main IPG screen is displayed.
- 2 Use the ◀ or ▶ arrow key to highlight the **PERSONAL** button in the **Service** menu.
- 3 Press the ▲ or ▼ arrow key to highlight **Select 4-Digit Code**. Press **Select**.
The screen requiring you to enter your current code will be displayed.
- 4 Enter the current code. If it is still the default code, then it will be 0000. Press **Select**.
The screen requiring you to enter a new 4-digit code (of your choice) will be displayed.
- 5 Enter your new 4-digit code. Press **Select**. The screen requiring you to confirm your new code will be displayed.
- 6 Re-enter your new code and press **Select**. The main IPG will then be displayed.
Press **Exit** to return to normal viewing.

NOTE: If you enter the wrong code in the confirmation screen, the **ENTER NEW 4-DIGIT CODE** screen will again be displayed. Re-enter and re-confirm your new code.



ACCOUNT STATUS *(Not yet available.)*

The **Account Status** option enables you to view the status of your account.

To access **Account Status**:

- 1** While in normal viewing mode, press **Select** on the remote control. The main IPG screen is displayed.
- 2** Use the ◀ or ▶ arrow key to highlight the **PERSONAL** button in the **Service** menu.
- 3** Press the ▲ or ▼ arrow key to highlight **Account Status**. Press **Select**. The screen requiring you to enter your 4-digit code is displayed.
- 4** Enter the 4-digit code and press **Select**. The **Account Status** screen is displayed.

PAY-PER-VIEW ACCOUNT *(Not yet available.)*

The **Pay-Per-View Account** option enables you to view the status of your Pay-Per-View Account.

To access **Pay-Per-View Account**:

- 1** While in normal viewing mode, press **Select** on the remote control. The main IPG screen is displayed.
- 2** Use the ◀ or ▶ arrow key to highlight the **PERSONAL** button in the **Service** menu.
- 3** Press the ▲ or ▼ arrow key to highlight **Pay-Per-View Account**. Press **Select**. The screen requiring you to enter your 4-digit code is displayed.
- 4** Enter the 4-digit code and press **Select**. **Pay-Per-View Account** screen is displayed.

PAY-PER-VIEW PIN

The **Pay-Per-View PIN** option enables you to set your Pay-Per-View PIN so that access to the Pay-Per-View Account is limited to those who know the PIN.

To access **Pay-Per-View PIN**:

- 1 While in normal viewing mode, press **Select** on the remote control. The main IPG screen is displayed.
- 2 Use the ◀ or ▶ arrow key to highlight the **PERSONAL** button in the **Service** menu. Press the ▲ or ▼ arrow key to highlight **Pay-Per-View PIN**. Press **Select**. The screen requiring you to enter your 4-digit code is displayed.
- 3 Enter the 4-digit code and press **Select**. The **Pay-Per-View PIN** screen is displayed.
- 4 Highlight On or Off using the ▲ or ▼ arrow keys, then press **Select** to set your **Pay-Per-View PIN** to on or off.
- 5 Press **Exit** to return to normal viewing.

SET PAY-PER-VIEW LIMIT *(Not yet available.)*

The **Set Pay-Per-View Limit** option enables you to set your **Pay-Per-View Limit**. This limit controls the individual Pay-Per-View movie or event purchase maximum price. Beyond the set maximum requires the use of your 4-digit PIN.

To access **Pay-Per-View Limit**:

- 1 While in normal viewing mode, press **Select** on the remote control. The main IPG screen is displayed.
- 2 Use the ◀ or ▶ arrow key to highlight the **PERSONAL** button in the **Service** menu.
- 3 Press the ▲ or ▼ arrow key to highlight **Pay-Per-View Limit**. Press **Select**. The screen displaying the current pay-per-view-limit, and requiring you to enter your 4-Digit code is displayed.
- 4 Enter the 4-digit code and press **Select**. The screen requiring you to enter your **Pay-Per-View Limit** is displayed.
- 5 Please note that the **Pay-Per-View Limit** is entered in cents, eg., if you want to set your limit to \$40, then just enter 4000. If you enter in a wrong amount, or if you would like to change the amount you have entered, press the ◀ (left) arrow key to delete the incorrect amount, and re-enter the correct amount. Press **Select**. You will be returned to the Main Menu.
- 6 Press **Exit** to return to normal viewing.



SELECT SAP PREFERENCE

The **Select SAP Preference** option allows you to select your first audio language choice.

To access **Select SAP Preference**:

- 1 While in normal viewing mode, press **Select** on the remote control. The main IPG screen is displayed.
- 2 Use the ◀ or ▶ arrow key to highlight the **PERSONAL** button in the **Service** menu.
- 3 Press the ▲ or ▼ arrow key to highlight **Select SAP Preference**. Press **Select**.
- 4 Highlight the language of your choice using the ▲ or ▼ arrow key. Press **Select**.
- 5 Press **Exit** to return to normal viewing.

STEREO SETTINGS

The **Stereo Settings** option allows you to select your first AC3 Downmixing and SPDIF Output Settings.

To access **Stereo Settings**:

- 1 While in normal viewing mode, press **Select** on the remote control. The main IPG screen is displayed.
- 2 Use the ◀ or ▶ arrow key to highlight the **PERSONAL** button in the **Service** menu.
- 3 Press the ▲ or ▼ arrow key to highlight **Stereo Settings**. Press **Select**. Press **Select**.
- 4 The settings for **AC3 Downmixing** will be highlighted in the left menu. Press the ▲ or ▼ arrow keys to select **Normal Stereo** or **Dolby Stereo**. Press **Select**.
- 5 Press the ▶ (right) arrow key to select **SPDIF Output**, and press the ▲ or ▼ arrow keys to select **Decoded PCM** or **Undecoded AC3**. Press **Select**.
- 6 Press **Exit** to return to normal viewing or **GO BACK** to return to main IPG.



REMINDER SETTINGS

The **Reminder Settings** option allows you to automatically tune to programs with set reminders.

To access **Reminder Settings**:

- 1 While in normal viewing mode, press **Select** on the remote control. The main IPG screen is displayed.
- 2 Use the ◀ or ▶ arrow key to highlight the **PERSONAL** button in the **Service** menu.
- 3 Press the ▲ or ▼ arrow key to highlight **Reminder Settings**. Press **Select**.
- 4 Highlight **Auto Retune** or **No, Don't Retune** using the ▲ or ▼ arrow key. Press **Select**.
- 5 Press **Exit** to return to normal viewing.

BANNER DURATION

The **Banner Duration** option allows you to set the length of time the banner will be displayed.

To access **Banner Duration**:

- 1 While in normal viewing mode, press **Select** on the remote control. The main IPG screen is displayed.
- 2 Use the ◀ or ▶ arrow key to highlight the **PERSONAL** button in the **Service** menu.
- 3 Press the ▲ or ▼ arrow key to highlight **Banner Duration**. Press **Select**.
- 4 Using the ▲ or ▼ arrow key, highlight the preferred amount of time you desire the banner to be displayed. Press **Select**.
- 5 The screen requiring you to set the time for **Program Reminders** will be displayed.
- 6 Press the ▲ or ▼ arrow keys and highlight the amount of time you want a reminder banner to be displayed before a reserved program starts. Press **Select**.
- 7 Press **Exit** to return to normal viewing.



SETTINGS

The **SETTINGS** option in the Service Menu gives you access to technical information about the CONVERTER BOX. You will not use these menus for normal operation of the CONVERTER BOX. However, the technical information listed under the **SETTINGS** option is important when calling a service center or your service provider.

FOR RCN TECHNICAL TEAMS ONLY.

Do not access SETTINGS unless requested by Customer Care.

CUSTOMER WARNING!!!

DO NOT ATTEMPT TO MAKE ANY CHANGES IN THE SETTINGS OPTION MENUS. DOING SO COULD CAUSE YOUR RCN DIGITAL CABLE BOX TO BECOME INOPERABLE. ALWAYS CALL YOUR SERVICE PROVIDER, OR AN ACCREDITED SERVICE CENTER IF YOU NEED TO MAKE ANY CHANGES IN THE SETTINGS OPTION MENUS.

To access the **SETTINGS** option do the following:

- 1 While in normal viewing mode, press **Select** on the remote control.
- 2 Use the ◀ or ▶ arrow buttons to highlight the **SETTINGS** button in the Service menu. When **SETTINGS** is highlighted, the Menu Options (the left part of the screen) changes.
- 3 The relevant technical subjects will be displayed in the Menu Options area of the IPG.
- 4 Use the ▲ and ▼ arrow keys to scroll through the technical subjects. If you press the ? key, **Exclusive application for engineers** will be displayed over the IPG.
- 5 To exit the IPG and return to normal viewing, press **Select** on the remote control.

BANNERS/FLIP BAR

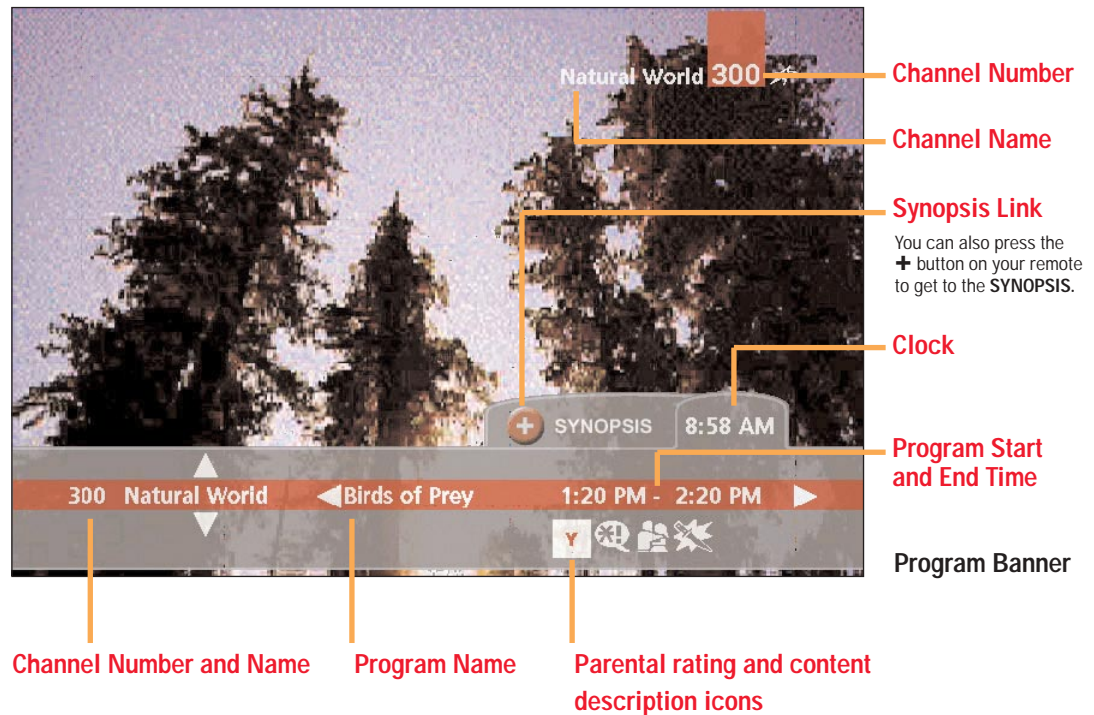

In addition to the Main Menu and IPG screens, the viewer can also control the RCN Digital Cable Service through Banners. All the banners are displayed towards the bottom of the screen, and occupy most of the screen width. All the banners overlay the video.

PROGRAM BANNER

The **Program Banner** gives access to information on the current and subsequent programs on the current channel, and current and forthcoming programs on other channels. The **Program Banner** can access programs scheduled for broadcast between the current local time and 24 hours in the future.

To access the **Program Banner**:

- 1 Press ? on the remote control while viewing a program. The program banner will be displayed.
- 2 The program banner will also be automatically displayed when the channel is changed. The banner will remain on screen for the duration that is set in the IPG. See **Banner Duration** on [page 33](#).
- 3 Press the ▲ and ▼ arrow keys to scroll through the titles of channels, and press the ◀ and ▶ arrow keys to scroll through titles of programs.
- 4 Press ? to remove the **Program Banner**.



SYNOPSIS TEXT BANNER

The **Synopsis Text Banner** shows a textual description of the program currently selected on the **Program Banner**.

To access the **Synopsis Text Banner**:

- 1 Press **+** while the **Program Banner** is displayed. The **Synopsis Text Banner** will be displayed over the video.
- 2 Press **?** to remove the **Synopsis Text Banner**.
- 3 Press **?** to remove the **Program Banner**.

LANGUAGE BANNER

The **Language Banner** shows the currently selected audio and subtitle language, and also allows you to change the language for the program audio and subtitles.

To access the **Language Banner**:

- 1 Press **+** while viewing a program. The **Language Banner** will be displayed over the video.
- 2 Press the **▲** and **▼** arrow keys to scroll through the other audio languages, and press the **◀** and **▶** arrow keys to scroll through other subtitle languages.
- 3 Press **+** to remove the **Language Banner**.

SETTING A REMINDER WITHIN THE PROGRAM BANNER

Programs that start in the future can also be set as reminders via the **Program Banner**.

To set a reminder via the **Program Banner**:

- 1 Press **?** on the remote control. When the **Program Banner** is displayed, press the **▲** or **▼** arrow key until the title of the desired channel is displayed.
- 2 Then press the **▶** arrow key until the title of the program you want to book is displayed. Press **Select**.
- 3 Press **Select** to book the program. Ensure that a check mark appears in the black box next to the program name after you push **Select**.
- 4 Press **Exit** twice to return to normal viewing.

SETTING REMINDERS FOR A PAY-PER-VIEW PROGRAM VIA THE PROGRAM BANNER

Pay-Per-View Programs that start in the future can also be booked via the **Program Banner**.

To set a reminder via the **Program Banner**:

- 1 Press **?** on the remote control. When the Program Banner is displayed, press the **▲** or **▼** arrow key until the title of the desired channel/Pay-Per-View movie/event is displayed.
- 2 Then press the **◀** or **▶** arrow key until the title of the Pay-Per-View program you want to set up a reminder for is displayed.
- 3 Press **Select**.
- 4 Press **Select** to set a Reminder for the Pay-Per-View program.
- 5 Press **Select** to confirm order. In some instances your 4-digit code will be required when purchasing a Pay-Per-View program. Enter your 4-Digit code and press **Select**. The screen listing all the reminder Pay-Per-View programs will be displayed. Ensure that a check mark appears in the black box next to the program name after you push **Select**.
- 6 Press **Exit** twice to return to normal viewing.

REMINDER NOTIFICATION BANNER

The Reminder Notification Banner is displayed on screen just before a program with a set reminder starts. The number of minutes that the banner appears before the start of the program is selected in the **Banner Duration** menu in the IPG.

- 1 The following screen is displayed before the start of a booked program.



Reminder Notification Banner

- 2 Press **Select** to confirm the booking, or press **GO BACK** to cancel the booking. If the booking is confirmed, the converter box will automatically switch to the correct channel when the program starts. If the booking is neither cancelled nor confirmed, the IPG will automatically tune to the channel showing the program for which the reminder was set.
- 3 Follow the on-screen prompts and confirm or cancel the booking.



STARVIEWSM

RCN Digital Cable supports Starview which provides a flexible way to navigate to other programming channels. Each Starview channel is a matrix of channels which is transmitted as a single video image. There are seven Starview channels beginning on channel 100.

STARVIEW GENRE CATEGORIES:

Local

Movies

Entertainment

Lifestyles

News

Kids

Sports

To access **Starview**:

- 1 While in normal viewing mode, press **Starview** on the remote control. Your television will automatically tune to the local Starview channel.

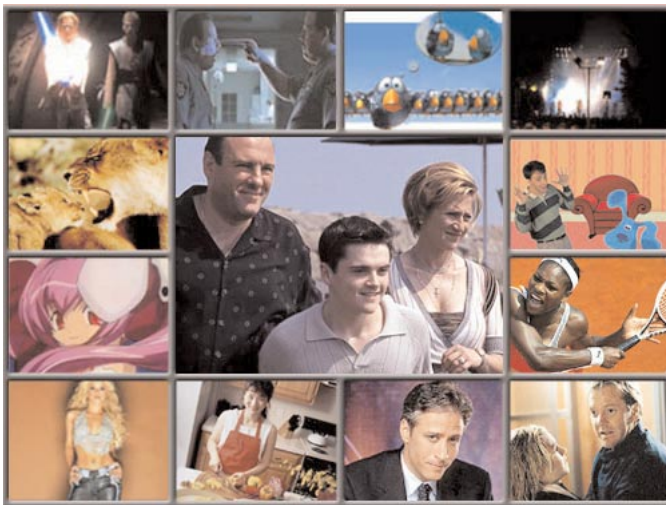

Starview



STARVIEW

Press the **Starview** button on the remote control while in normal viewing mode.

- 2 The remote control enables you to move a cursor around the Starview guide using the arrow keys. Move the cursor onto a channel you would like to watch and press **Select**. The converter box will tune to that channel.
- 3 The above figure shows a promotional mosaic. This mosaic contains a large, central promotional cell with single cells all around it. The single cells contain live video from a number of channels, while the promotional cell is used to run live video promotional features and instructional videos.

INTERACTIVE APPLICATIONS

WHAT ARE INTERACTIVE APPLICATIONS?

Interactive applications are new services that can be accessed through RCN's digital set top box. Many of these services, called virtual channels, function similarly to Internet sites where the users can access and navigate through specific information. In addition, interactive applications also include simple games, where the customer uses the remote control to play a game through the set top box.



iPORTAL

What is iPortal? iPortal serves as a main menu for RCN's interactive applications by providing links to all of the applications from one convenient location. Customers use the arrow keys on the remote control to select the interactive application that they would like to access.

Accessing iPortal

RCN's interactive applications are accessed through iPortal.

There are two ways to access iPortal:

1) Press the **i** button on the remote control

OR

2) Tune to **channel 500**

Press **EXIT** on the remote control to return to live television.



RCN IMPULSE ON-DEMAND

3 WAYS TO ACCESS THE VOD MAIN MENU

– THROUGH iPORTAL

1. Press the **i** button on your remote control
2. The iPortal main page will appear on your screen
3. Using the arrow keys on your remote control, highlight the "**Impulse ON-DEMAND**" button
4. Press **Select** on the remote control

– TUNE TO CHANNEL 1

1. On your remote control, press "001"

– THROUGH THE INTERACTIVE PROGRAMMING GUIDE

1. Press **Select** on your remote control to access the IPG
2. Using the ◀ and ▶ arrow keys on the remote control, highlight **Guide** at the top of the screen
3. Using the ▲ and ▼ arrow keys, highlight **Impulse ON-DEMAND** in the menu on the left side of the screen
4. Press **Select** on the remote control

OR

1. Press **Select** on your remote control to access the IPG
2. Using the ◀ and ▶ arrow keys on the remote control, highlight **Channels** at the top of the screen
3. Using the ▲ and ▼ arrow keys or the **Channel Up/Down** (which also functions as page up/down), highlight channel number 1 "**Impulse ON-DEMAND**" in the channel line up menu
4. Press **Select** on the remote control

ORDERING A MOVIE

1. Access **VOD Main Menu** screen
2. Using the arrow navigation buttons on the remote control, highlight the "**RCN Impulse ON-DEMAND**" button
3. Press **select** and the "On Demand Main Menu" screen will be displayed.
4. "**Select Movie**" will be highlighted at the bottom of the screen. On remote control press **select**, and the icon will change to a grey color.
5. The next screen will display:
 - a. My rentals
 - b. Previews
 - c. New Releases
 - d. \$2.99 Movies
 - e. Double Features
 - f. Holiday Movies
 - g. Free on Demand
 - h. HBO on Demand

Arrow key to page down, a new screen will appear listing the following options:

- a. HBO on Demand
 - b. Max on Demand
 - c. Kids Unlimited
 - d. Spanish
 - e. Events
 - f. ESPN
 - g. Adult
6. Choose one of the above categories by using the ▲ or ▼ on the remote. Press **select** to choose category.
 7. Using ▲ or ▼ arrow keys on the remote control, highlight the movie you would like to watch.
 8. After selecting the movie, a synopsis of the movie appears, along with:
 - a. Rating of movie
 - b. Length of Movie
 - c. Rental time Left
 - d. Price
 9. To purchase movie highlight "**Buy**" and press **Select**.
 10. Next screen will confirm what you have chosen to order.



11. Highlight "OK" if you would like to continue with the purchase. And press **Select**.
12. The next screen will ask you to enter PIN number, if you have set up a PIN
13. Enter 4-Digit PIN and use the ▼ arrow key to select "OK." Press **Select**.
14. A new screen appears that confirm the movie that you purchased, including:
 - a. Rating of movie
 - b. Length of Movie
 - c. Rental time Left
 - d. Price

This screen also includes a diagram of the remote control on the left side of the screen:

▲	Play
▼	Pause
▶	Fast Forward
◀	Rewind
Red Button	Stop
Green Button	Restart
Blue Button	Hide

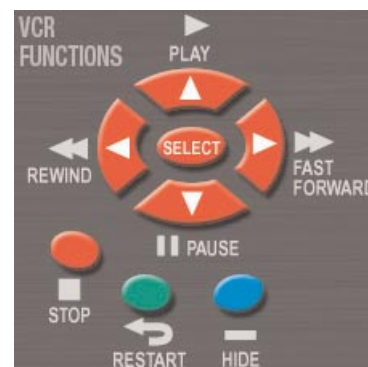

15. The movie should automatically start after this screen appears for 5 seconds

RESUME IMPULSE ON-DEMAND VOD

1. Access **Impulse ON-DEMAND (VOD)** Main Menu screen
2. Highlight the "**Resume Movie**" icon at the bottom of the screen. Press **Select**.
3. A list of previously purchased movies will appear. Using the arrow keys on the remote control, highlight the movie you would like to resume watching. Press **Select** on the remote control.
4. After selecting the movie, a synopsis of the movie appears, along with:
 - a. Rating of movie
 - b. Length of Movie
 - c. Rental time Left
 - d. Price
5. Using the arrow keys on the remote control, highlight one of the following icons at the bottom of the screen:
 - a. Continue (to continue where you stopped watching previously)
 - b. Restart (to restart the movie from the beginning)
6. Press **Select** on the remote control.
7. The next screen will ask you to enter PIN number.
8. Enter 4-Digit PIN and use the down arrow key to select "**OK.**" Press **Select**.
9. A new screen appears that confirm the movie that you purchased, including:
 - a. Rating of movie
 - b. Length of Movie
 - c. Rental time Left
 - d. Price

This screen also includes a diagram of the remote controls. (See previous page.)
10. The movie should automatically start after this screen appears for 5 seconds



Pay-Per-View

Accessing Pay-Per-View

1. Access the desired Pay-Per-View channel (3 options):
 - a. Tune directly to the channel by typing the channel number on your remote control (301 & 316 – 323)
 - b. Press **Guide** on the remote control to invoke the **TV listing menu**, scroll up/down to the desired PPV channel, press **Select**.
 - c. Press **Select** on the remote control to invoke the IPG, use the left/right arrow keys to highlight **CHANNELS** in the **Service Menu**, use the up/down arrow keys to scroll through the list of channels until you highlight the desired PPV channel, press **Select** to view the PPV channel in the video window, press **Select** again to tune to the highlighted PPV channel.

Note: If the movie has already begun and it is beyond the window to order the movie/event, a screen will appear with the following text: "Sorry, you can no longer purchase this Pay-Per-View program (channel #)."

2. A screen will appear with the following information:
 - Title of movie/ppv event
 - Start time and end time of movie
 - Price
 - Rating
 - Synopsis
3. Press **Select** on the remote control.
4. A screen will appear with the following information:
 - Title of movie/ppv event
 - Price
 - If the program has already started, the following message will also appear: "Program has already started."

If you have set up a Pay-Per-View PIN, this screen will also require the 4-digit PIN.

5. Press **Select**.
6. The program will begin at the scheduled time.

Zone4Play

Access:

1. Access iPortal by pressing the **i** button on the remote control or tuning to channel 500.
2. Using the arrow keys on the remote control, highlight the **Zone4Play** button on the screen.
3. Press **Select/OK** to enter the Zone4Play casino "lobby".
4. Using the arrow keys on the remote control, highlight the Zone4Play casino game that you would like to play.
5. Press **Select/OK** to enter the Zone4Play casino game that you have highlighted.

Play:

Once you have accessed a Zone4Play casino game, the arrow keys on the remote control are used for basic functionality. The blue, green, yellow, and red buttons on the remote control are used for additional when needed. The customer can access the "Help" section of the casino game by pressing the **?** button on the remote control.

Interactive Weather

1. Access iPortal by pressing the **i** button on the remote control or tuning to channel 500.
2. Using the arrow keys on the remote control, highlight the **Weather** button on the screen.
3. Press **Select/OK** to enter the main weather page.
4. Use the arrow keys on the remote control to navigate through the sections of the weather application.

Interactive Horoscopes

1. Access iPortal by pressing the **i** button on the remote control or tuning to channel 500.
2. Using the arrow keys on the remote control, highlight the **Horoscope** button on the screen.
3. Press **Select/OK** to enter the main Horoscope page.
4. Use the arrow keys on the remote control to highlight the desired zodiac sign and press **Select/OK**.

Return Procedures

Return to Live Television Program

At any time within the interactive applications, you can press **EXIT** on your remote control to exit the interactive applications and return to the last television network that you were watching.

Return to iPortal

At any time within the interactive applications, you can press **i** on your remote control return to iPortal.



NAVIGATING TO PROGRAMS

Navigating to programs can be done in the following ways:

- by using the **CHANNEL UP** and **CHANNEL DOWN** buttons to surf through the channels,
- by directly entering the channel number using the numeric keys on the remote control,
- by using the program guide,
- by navigating from the Program Banner,
- by selecting a program type (genre) from the IPG category, then selecting a program from the list,
- by selecting a program from the TV LISTINGS menu,
- by selecting from Starview,
- by selecting from the IPG list of digital music channels.

VOLUME AND MUTE

The RCN digital converter box allows you to set the volume to a variable level only. This should be taken into consideration when recording programs via your VCR.

- 1** Press the **VOLUME UP** key on the remote control to increase the volume, and press the **VOLUME DOWN** key to decrease the volume.
- 2** A volume bar indicating the volume level will be displayed at the bottom of the screen, and will move from left to right when the volume is increased, and from right to left when the volume is decreased.
- 3** To mute the audio, press the **MUTE** key on the remote control. A mute icon will be displayed on the left corner of the screen.
- 4** To restore the volume press **MUTE** or **VOLUME UP** or **VOLUME DOWN**.

PROBLEM	SOLUTION
No picture	<ul style="list-style-type: none">• Ensure that the CONVERTER BOX, TV and all relevant equipment are switched on and connected properly.• Check the connection cables.• Ensure that the CONVERTER BOX is not in standby mode.• Check the power cable and check that it is plugged into the power outlet.
No or low sound	<ul style="list-style-type: none">• Turn up the volume on the TV.• Check that the mute function is not on.• Ensure that all the equipment is connected properly.• Check the connection cables.
Herringbone pattern or faint lines on TV	<ul style="list-style-type: none">• Adjust fine tuning on the TV.• Check connection cables.• A service call may be necessary — 1.800.RING.RCN.
CONVERTER BOX does not respond to remote control	<ul style="list-style-type: none">• Point remote control directly at the CONVERTER BOX front panel.• Check the batteries of the remote control.• Check if remote control is in CONVERTER BOX mode.
On screen message : ONE MOMENT PLEASE	If the CONVERTER BOX does not move from this screen more than 5 minutes after start up. it means the converter box has lost communication. Call RCN — 1.800.RING.RCN.
On screen message : NO SIGNAL	Check the cable signal. Call RCN — 1.800.RING.RCN

IF YOU ENCOUNTER ANY OTHER ERRORS PLEASE CONTACT RCN.

1.800.RING.RCN.



Telephone 1.800.RING.RCN (1.800.746.4726)

Web site www.rcn.com

E-MAIL

SALES

- Residential sales@rcn.com

- Commercial commercial@rcn.com

SERVICE AND SUPPORT

- Dial-Up Internet dialuphelp@rcn.com

- Cable Modem cablemodemhelp@rcn.com

- Cable TV cabletv@rcn.com

- Phone phone@rcn.com

- Commercial commercial.service@rcn.com

- ResiLink phone@rcn.com

Manufacturer's Web site www.uec.co.za

